

## Chapter -1

# The Fish Jumps

Q.1. Fill in the blanks :

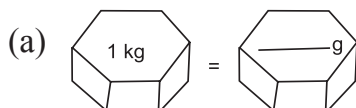
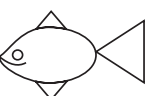

(b)  \_\_\_\_\_, \_\_\_\_\_, \_\_\_\_\_ shapes are used to draw this fish.

Q.2. State true or false

(a) The place value of 7 in number 3729510 is 7 lakh. ( )

(b) 5500 g can also be written as 5 kg 500 gms. ( )

Q.3. Match numerals of fish A with number names of fish B.

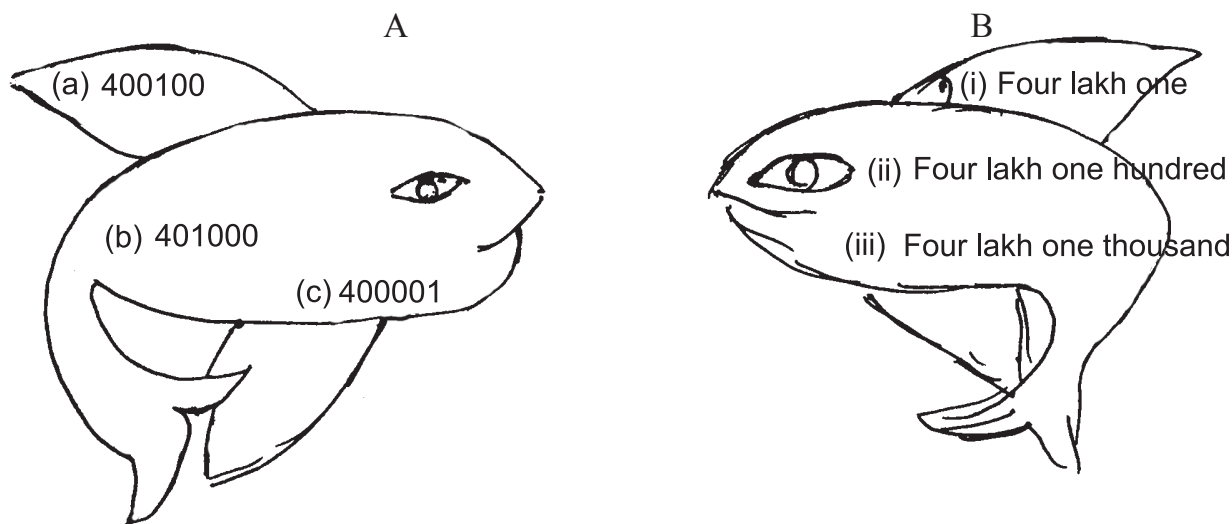

Q.4. Write numerals for the following number names.

(a) Six lakh twenty five thousand one hundred and six : \_\_\_\_\_

(b) Ten lakh twenty five thousand \_\_\_\_\_

Q.5. There are 6 milestones on a way. Each milestone is at a distance of 1000 m. Find the total distance between second and sixth milestone. Also convert the answer in km.

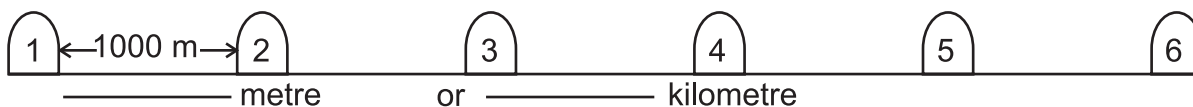

Q.6. In an aquarium each fish has a weight 250 g. Find the total weight of all the fishes and convert into kg.

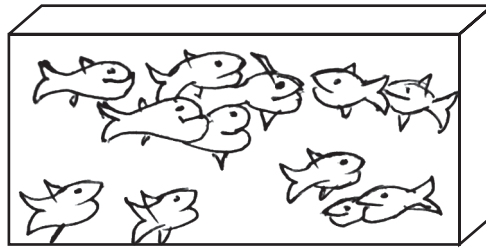

- (a) Total number of fishes = \_\_\_\_\_  
 (b) Total weight of fishes = \_\_\_\_\_ g or = \_\_\_\_\_ kg.

Q.7. Write the expanded notation of :

- (1) 126504 =  
 (2) 4066903 =

Q.8. Write the numbers

$$\begin{array}{r}
 600000 \\
 + 7000 \\
 + 200 \\
 + 10 \\
 + 2 \\
 \hline
 = \boxed{\phantom{000000}}
 \end{array}$$

$$\begin{array}{r}
 2,00,000 + 40,000 \\
 + 3000 + 700 + \\
 30 + 0 \\
 \hline
 = \boxed{\phantom{000000}}
 \end{array}$$

Q.9. Count in lakhs.

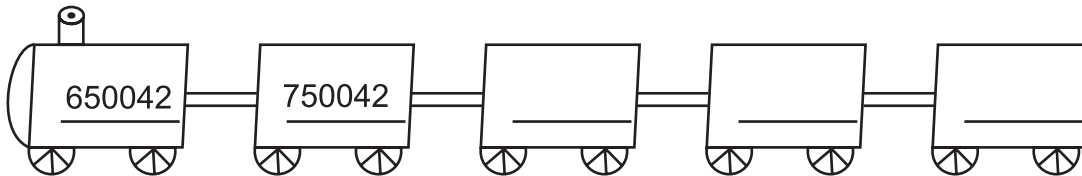

Q.10. Build the greatest and smallest numbers using 2, 5, 3, 7, 9 and 0. Each number should be used once.

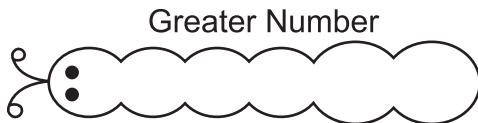

Q.11. Following weights of different measures are given. Use these weights in different combinations to make total weight of 7000 g or 7 kg.

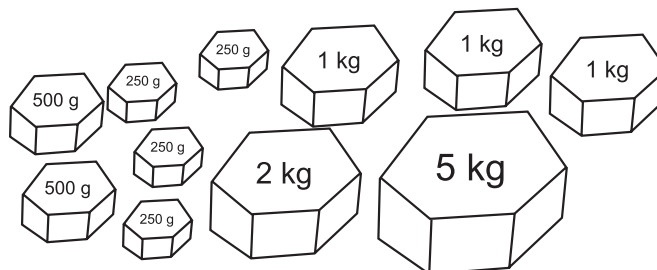

(a)

(b)

(c)

(d)

- Q.12. A farmer plants saplings at a distance of 2 m from each other. If there are 7 saplings in each row, what will be the distance between the first and the last sapling? Draw the remaining saplings also.

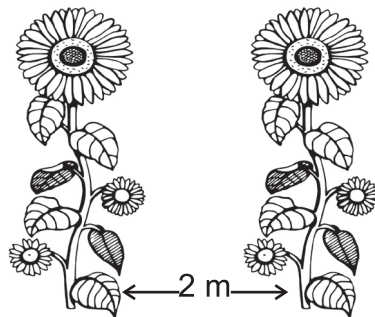

- Q.13. Solve the following :

90	×	30	-	500	+	80	=	
----	---	----	---	-----	---	----	---	--

- Q.14. Express the following in m and cm

(a) 375 cm = \_\_\_\_\_

(b) 903 cm = \_\_\_\_\_

- Q.15. Express the following in cm =

(a) 4 m 50 cm = \_\_\_\_\_

(b) 7 m 01 cm = \_\_\_\_\_

## Chapter-2

# Shapes and Angles

Q.1. Mark ✓ or ✗

(a)  is a closed figure. ( )

(b)  Alphabet L has one angle of  $90^\circ$ . ( )

Q.2. Match the following angles with their measurements :

(a)  (i) Less than right angle

(b)  (ii) Right angle or  $90^\circ$

(c)  (iii) More than right angle

Q.3. Circle the closed figure made of match sticks.

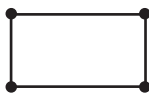
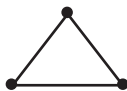
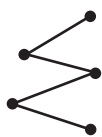

(a)

(b)

(c)

(d)

Q.4. In the word  mark the angles and complete the table:

S.No.	Name of angle	Number
1.	Right angle or $90^\circ$	
2.	Less than $90^\circ$	
3.	More than $90^\circ$	

Q.5. Measures these angles and write the measurement.

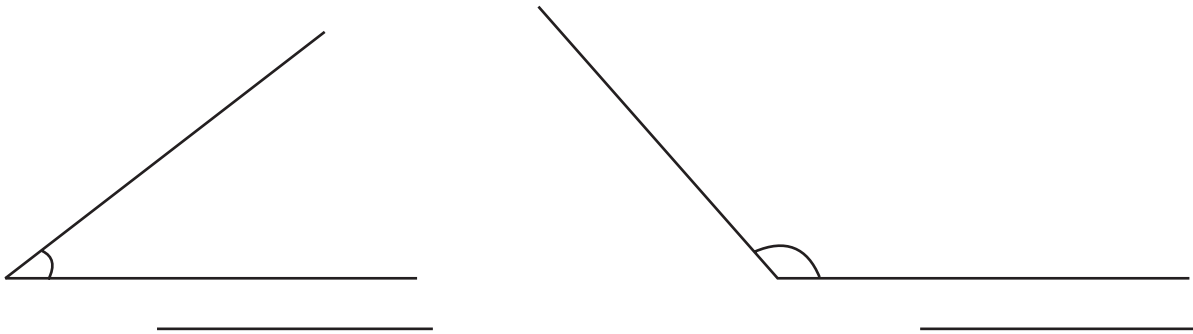

Q.6. Draw angles of following measures.

- (a)  $40^\circ$                       (b)  $120^\circ$

Q.7. Write the name of angles made by figures given below :

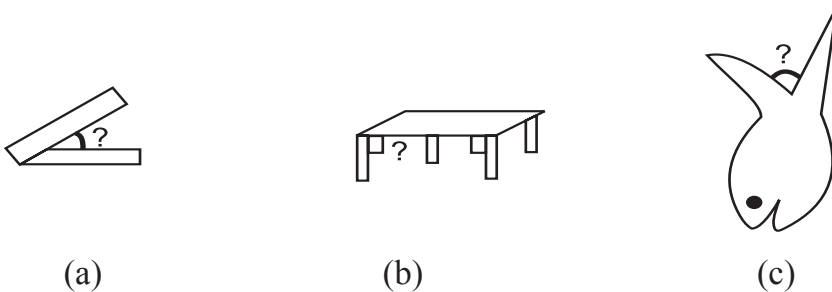

Q.8. Look at the watch carefully and answer the following questions.

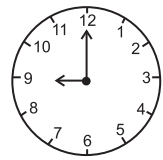

- (1) The time shown by the clock is \_\_\_\_\_.
- (2) The angle made by the hands at 9'O clock \_\_\_\_\_.
- (3) If the time shown by clock is 9:15 then the angle formed will be \_\_\_\_\_ degrees.
- (4) If its 1 'O' clock the angle made will be \_\_\_\_\_.
- (5) Half of  $90^\circ$  will be \_\_\_\_\_.
- (6) Half of  $180^\circ$  will be \_\_\_\_\_.

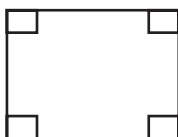
Q.9.  Each angle of the figure is of \_\_\_\_\_.

Q.10. How many angles are formed in each of the figures given below :

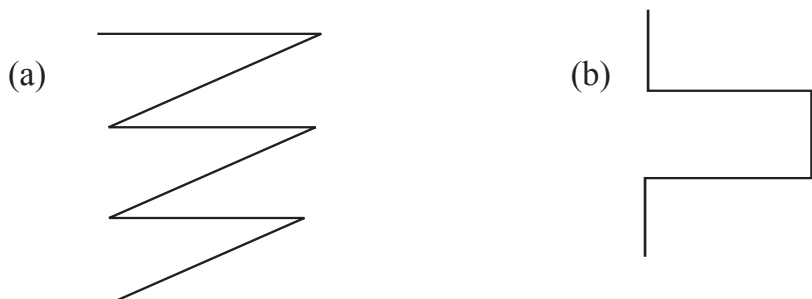

Chapter-3

# How many Squares

---

---

Q.1. Mark true or false.

- (a) We measure area in centimetres or metres. ( )
- (b) The amount of surface of the plane a closed plane figure covers is called its area. ( )

Q.2. Fill in the blanks :

- (a) The area of a square whose side is 1 cm is \_\_\_\_\_.
- (b) A square is considered to be the best unit of \_\_\_\_\_.

Q.3. Of the figures given below which figure has larger area?

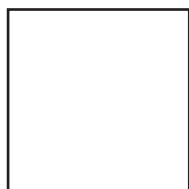

(a)

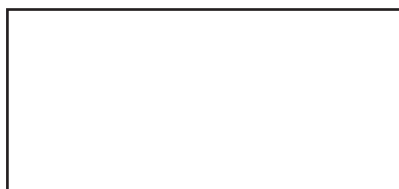

(b)

Ans. \_\_\_\_\_

Q.4. Of the figures given below which figure has smaller area?

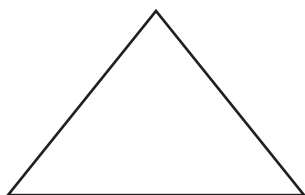

(a)

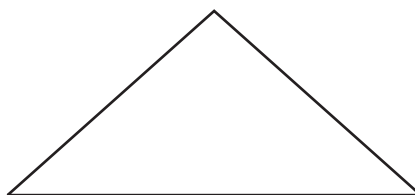

(b)

Ans. \_\_\_\_\_

Q.5. Find the area of the following by counting squares.

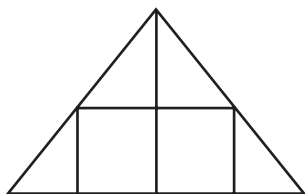

(a)

\_\_\_\_\_

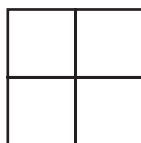

(b)

\_\_\_\_\_

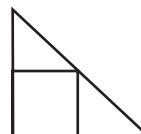

(c)

\_\_\_\_\_

Q.6. Which figure has larger perimeter? Table top or front page of book.

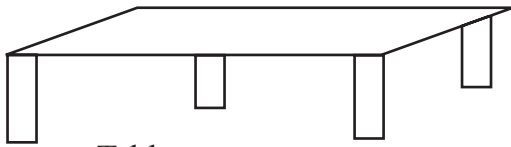

Table

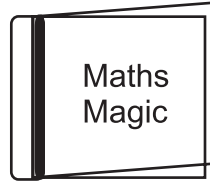

Ans. \_\_\_\_\_

Q.7. Find the area by counting squares. (Assume area of each small square as 1 sq cm.)

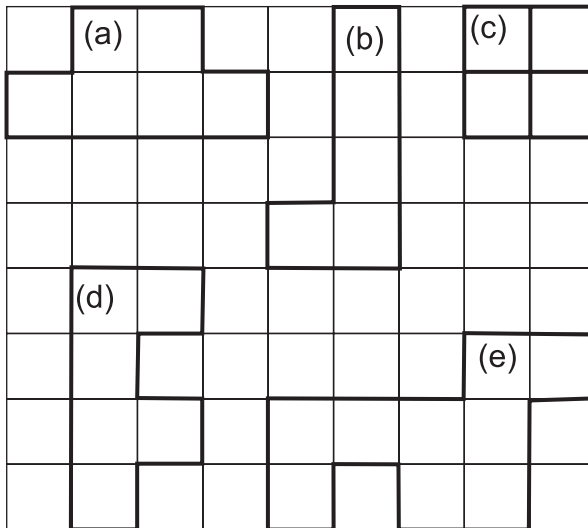

(a) \_\_\_\_\_

(b) \_\_\_\_\_

(c) \_\_\_\_\_

(d) \_\_\_\_\_

(e) \_\_\_\_\_

Q.8. You are given six squares, make maximum pictures in a grid and write their area one is done for you.

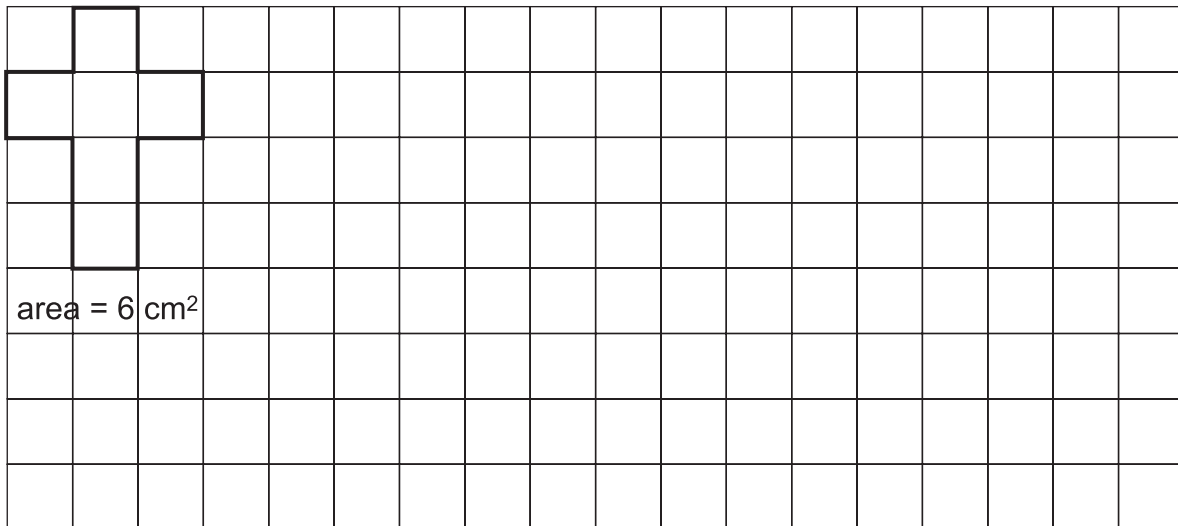

area = 6 cm<sup>2</sup>

Q.9. This is Monu's face  and this is Sonu's face . Whose face has more area?

## Chapter-4

# Parts and whole

---



---

Q.1. Mark ✓ or ✗

(a)  $\frac{1}{2} = \frac{2}{4} = \frac{3}{6} = \frac{4}{8}$  are equivalent fractions. ( )







(b)  $\frac{1}{9}, \frac{2}{9}, \frac{5}{9}$  are unlike fractions. ( )

Q.2. Fill in the blanks :

(a) This circle  is divided into \_\_\_\_\_ equal parts.

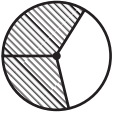
(b)  $\frac{1}{4}$  of this chocolate  will be \_\_\_\_\_ pieces.

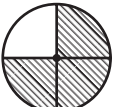
Q.3. Match column B with column A and C

Column A	Column B	Column C
(a) 	(i) $\frac{3}{4}$	(d) 
(b) 	(ii) $\frac{1}{2}$	(e) 
(c) 	(iii) $\frac{2}{3}$	(f) 

Q.4. Shade figure according to the given fraction :



(a)  $\frac{3}{5}$



(b)  $\frac{1}{8}$



Q.5. Make two equivalent fractions and represent in the picture.

(a)  $\frac{1}{3} = \underline{\hspace{2cm}} = \underline{\hspace{2cm}}$

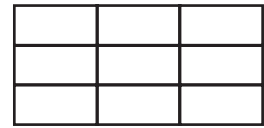
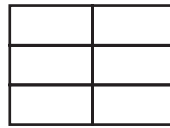

(b)  $\frac{2}{3} = \underline{\hspace{2cm}} = \underline{\hspace{2cm}}$

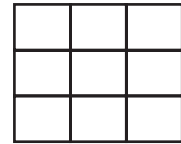
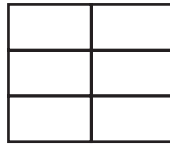

Q.6. You have to make ₹ 50 using ₹ 5 coin. How many such ₹ 5 coins you will require?

Q.7. Pinki decided to distribute 20 sweets to her friends. She gave  $\frac{1}{5}$  to Reema,  $\frac{2}{5}$  to Seema and remaining she kept for herself. Write number of sweets each one of them got.

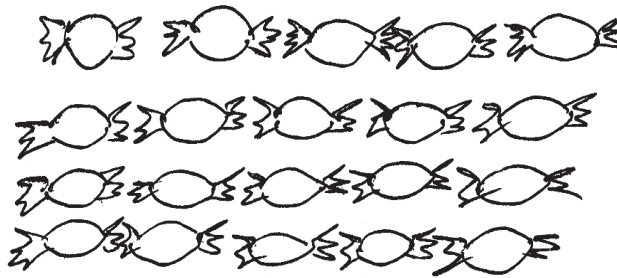

Reema

Seema

Pinki

Q.8.



There were 12 apples in a basket.  $\frac{1}{3}$  of apples became rotten. How many were left? Draw the remaining apples in the basket.



Ans. \_\_\_\_\_ apples left.

Q.9. Colour the grid according to given parts.

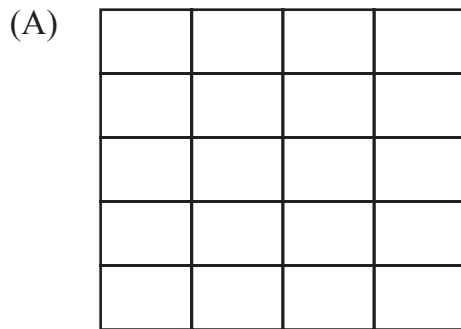

$\frac{10}{20}$  black,  $\frac{10}{20}$  yellow

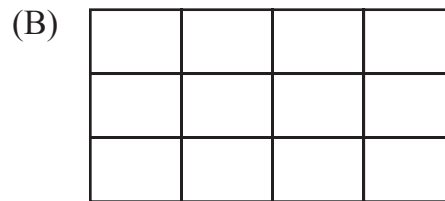

$\frac{4}{12}$  black,  $\frac{1}{2}$  yellow,  $\frac{2}{12}$  red.

Q.10. This is the rate list for following vegetables. If you have to go for shopping, how much will you pay to the vegetable seller?

<b>Rate List</b>	
Vegetables	Amount in Rupees (per kg)
1. Potatoes	18
2. Tomatoes	20
3. Lady finger	20
4. Radish	15

(a) What is the cost of 2 kg Potatoes?

Ans.

(b) What is the cost of  $\frac{1}{2}$  kg Potatoes?

Ans.

(c) What will be the cost of  $3\frac{1}{2}$  kg Potatoes?

Ans.

(d) What is the cost of 2 kg Radish?

Ans.

(e) What is the cost of  $1\frac{1}{2}$  kg Lady finger?

Ans.

(f) What is the cost of  $1\frac{1}{4}$  kg Tomatoes?

Ans.

Chapter-5

# Does it looks like the same?

---

---

Q.1. Q.1. Mark ✓ or ✗

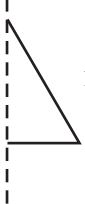
(a)  image in the mirror will make full view. ( )



(b) Alphabet U if turned  $\frac{1}{2}$  will look the same. ( )

Q.2. If ZOOM is turned half how will it look like?

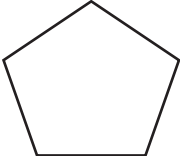
Q.3. If 1001 is turned half how will it look like?

Q.4.  This pentagon will have what shape if turned half?

Q.5. Complete these figures.

(a)  (b)  (c) 

Q.6. Draw any two shapes which if turned half looks the same?

Q.7. A, E, I, O, U vowels if turned half how will they look like? Draw them.

Q.8. if  $\div$  is turned  $\frac{1}{4}$ , how will it look like?

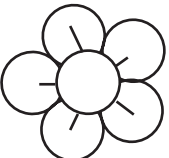
Q.9. How will this  look like if turned  $\frac{1}{5}$ ?

Q.10. Turn this  of  $\frac{1}{6}$ .

## Chapter-6

# Be my Multiple, be my Factor

---

---

Q.1. Circle the multiples of 9.  
10, 18, 27, 33, 36, 38, 45, 54, 57, 63

Q.2. Factors of 7 are 7 and \_\_\_\_\_.

Q.3. Fill the boxes :

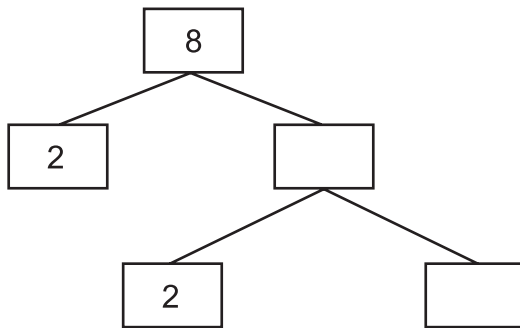

Q.4. State True/False  
Factors of 65 are 1, 5, 13, 65.

Q.5. Match the following :

**A**

- (i) Multiple of 5
- (ii) Greatest factor of 21
- (iii) Common factor of 2 and 5
- (iv) Divide the number by its factor, the remainder is

**B**

- (a) 1
- (b) 0
- (c) 100
- (d) 21

Q.6. Example :  
Factor of 9 : 1, 3, 9  
Factor of 15 : 1, 3, 5, 15  
Common factors : 1, 3

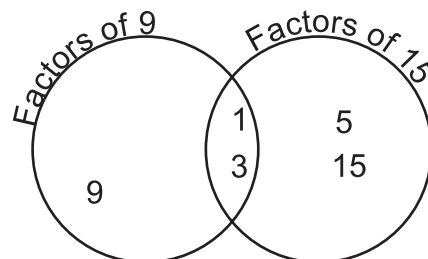

Now do this yourself

Factor of 12 : \_\_\_\_\_  
 Factors of 18 : \_\_\_\_\_  
 Common factors : \_\_\_\_\_

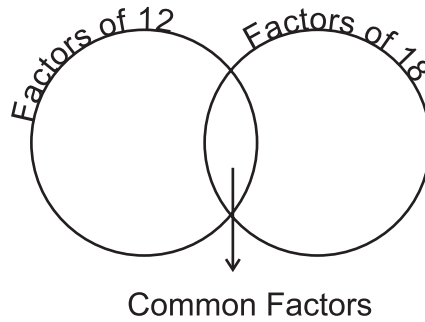

- Q.7. The multiple of 6 which is greater than 24 but less than 36 is \_\_\_\_\_.
- Q.8. A teacher divides 20 students into equal groups for an activity. Help her to make different groups.

Number of students in group	Number of groups
1	20
2	10
.	.
.	.
.	.

When the number of students in a group increases, the number of groups \_\_\_\_\_.

- Q.9. Which number has only one factor?
- Q.10. We can find the common multiples by using number line.

Example.

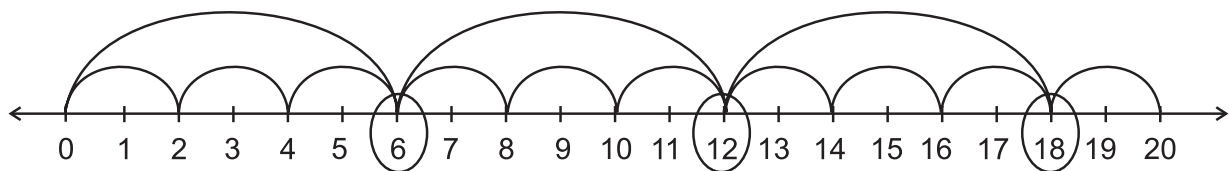

Common multiples of 2 and 6 = 6, 12, 18 .....

Now, do yourself :

Common multiples of 3 and 4 = ?

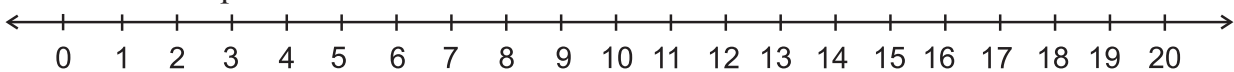

Chapter-7

# Can you see the Pattern?

Q.1. (A) What comes next? (Choose the correct option) :

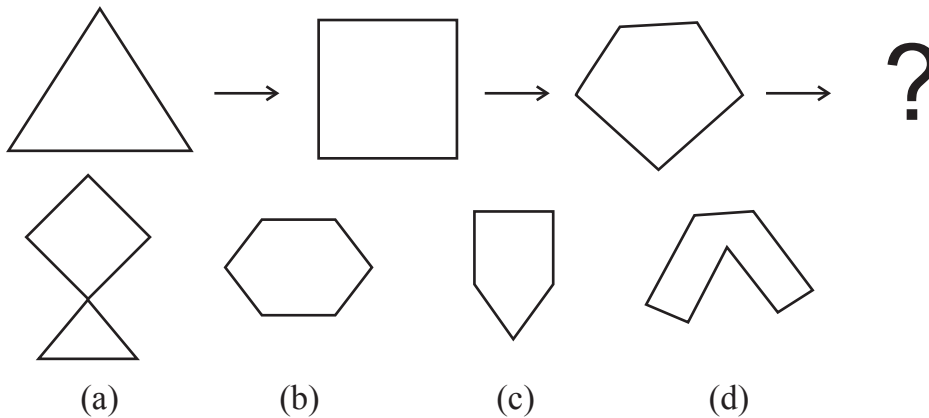

(B) ORANGE → RANG → ?

- (a) NG                      (b) ANG                      (c) AN                      (d) RAN

Q.2. Complete the series :

32, 40, 48, 56, \_\_\_\_\_, \_\_\_\_\_

Q.3. Fill in the blanks :

(a)  $39 + \underline{\hspace{1cm}} + 19 = 42 + 19 + \underline{\hspace{1cm}}$

(b)  $42 \times \underline{\hspace{1cm}} = 25 \times \underline{\hspace{1cm}}$ .

Q.4. Look at the pattern below and choose the correct answer :

$$(9 - 1) \div 8 = 1$$

$$(98 - 2) \div 8 = 12$$

$$(987 - 3) \div 8 = 123$$

$$(9876 - 4) \div 8 = \underline{\hspace{1cm}}$$

$$(98765 - 5) \div 8 = \underline{\hspace{1cm}}$$

- (a) 1234, 123456    (b) 1234, 12345    (c) 1235, 12356    (d) 1244, 1245

Q.5. Complete the magic square using all the numbers from 35 to 43 in the such a way that the total of each line is 117.

a	b	40
37	39	c
d	43	e

Q.6. Observe the pattern and fill in the boxes :

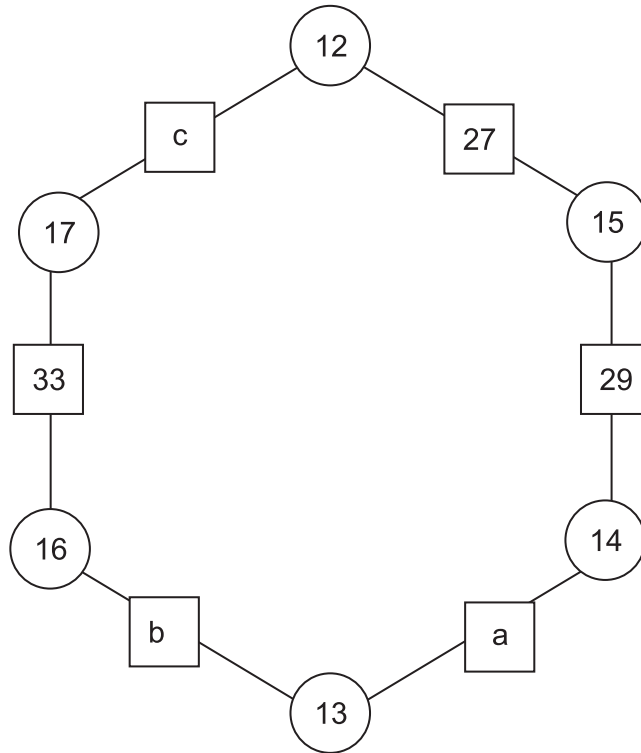

Q.7. What is the sum of  
 $1 + 3 + 5 + 7 + 9 + 11 + 13 = ?$

Q.8. How many  $\frac{1}{5}$  turns will be needed to bring the object back to its initial position?

Q.9. Which of these figures look the same on  $\frac{1}{3}$  turn?

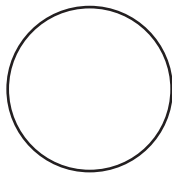

(a)

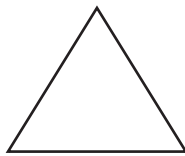

(b)

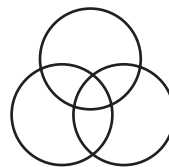

(c)

Q.10. What comes next? (Choose the correct option)

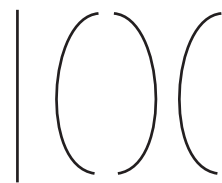
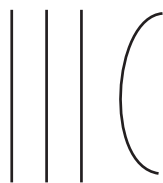
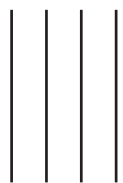

(a)

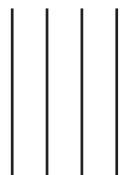

(b)

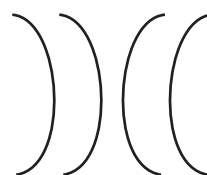

(c)

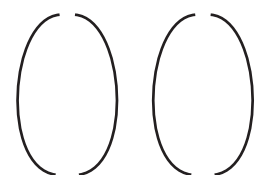

(d)



Q.11. Guesss the age

Step 1 : To your age add 10

Step 2 : Now double it.

Step 3 : From this subtract 20.

Step 4 : Divide it by two

The number you get is your age

Q.12. Complete the pattern

$$5 \times 5 = 25$$

$$55 \times 5 = 275$$

$$555 \times 5 = 2775$$

$$5555 \times 5 = \underline{\quad}$$

$$55555 \times 5 = \underline{\quad}$$

Chapter-8

# Mapping your Way

Q.1.

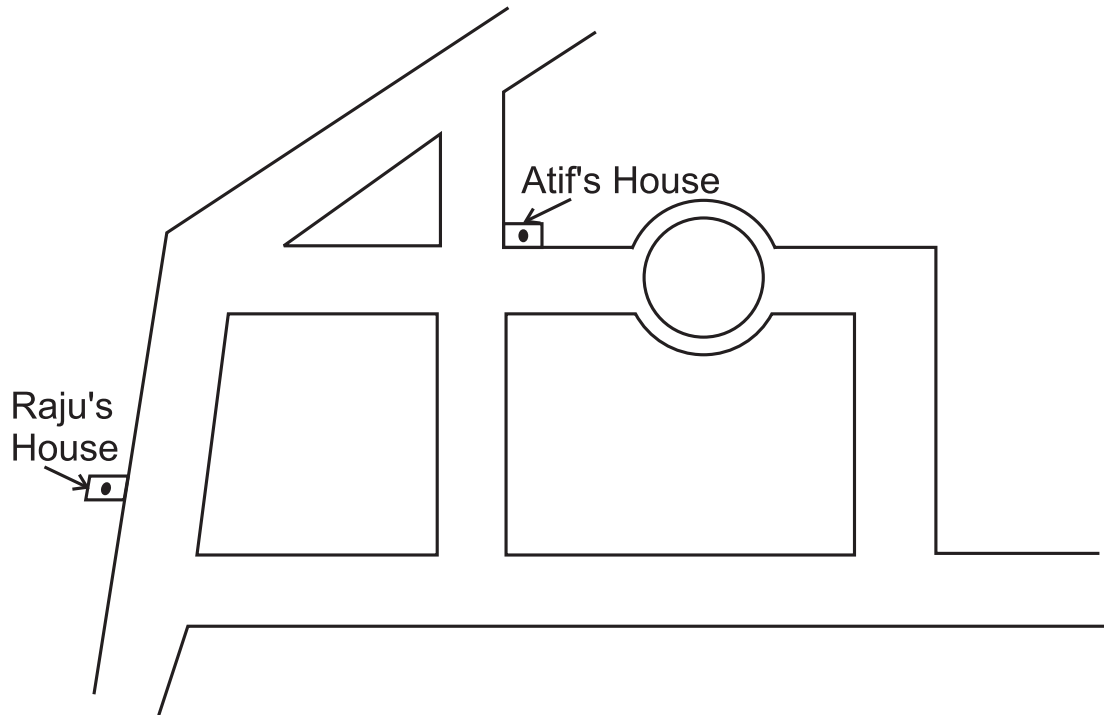

- (a) Mark the shortest route with arrows from Atif's house to Raju's house.
- (b) Mark the longest route with arrows from Raju's house to Atif's house.
- (c) How many routes he can take?

Q.2. The scale on a map is  $2 \text{ cm} = 1 \text{ km}$

If the distance shown on the map is 14 cm, what is the actual distance?

Q.3. If 1 cm on a map shows 50 km on the ground, how far is Ludhiana from Delhi?

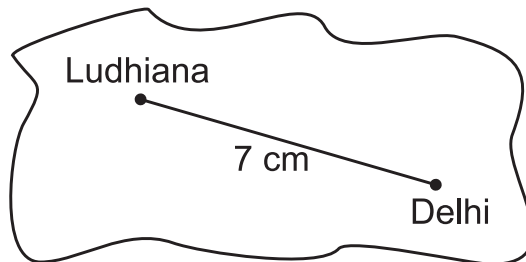

Q.4. Complete the table :

	Scale	Actual Distance	Distance on Map
A.	$\frac{1}{2}$ cm = 1 km	24 km	
B.	1 cm = 1 km	15 km	
C.	2 cm = 1 km		40 cm
D.	3 cm = 1 km	36 km	

Q.5.

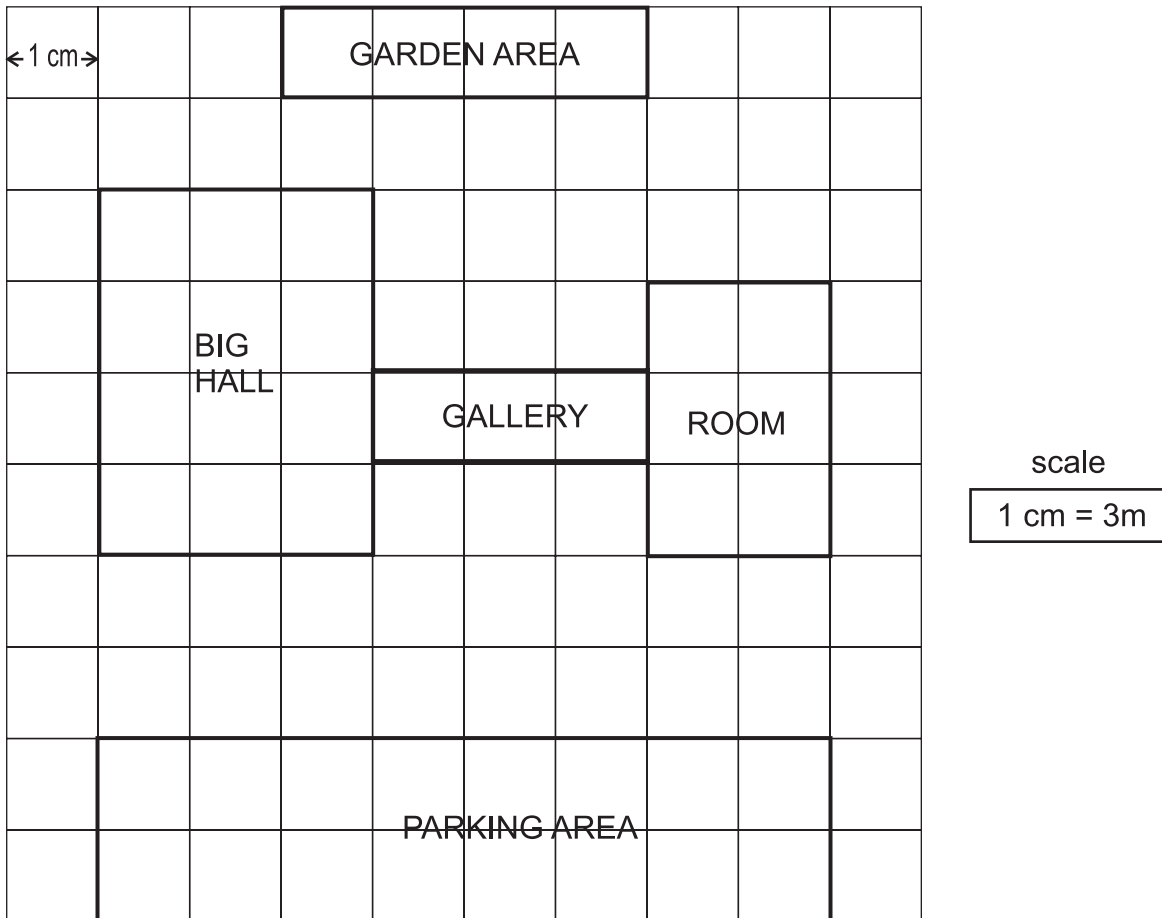

Use the squares to find out the area of :

- (A) Big Hall \_\_\_\_\_
- (B) Room \_\_\_\_\_
- (C) Gallery \_\_\_\_\_
- (D) Garden Area \_\_\_\_\_
- (E) Parking Area \_\_\_\_\_

# Boxes and Sketches

---

---

Q.1. Which of the following figures could be the face of a cube?

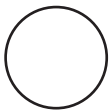

(a)

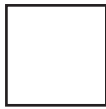

(b)



(c)

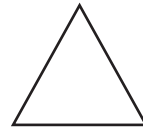

(d)

Q.2. Can  be folded into an open box?

Q.3. State True/False : All the faces of a cuboid are same.

True/False

Q.4. Which of the following is the drawing of a cubical box?

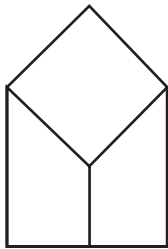

(a)

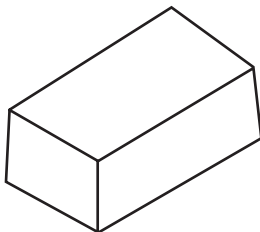

(b)

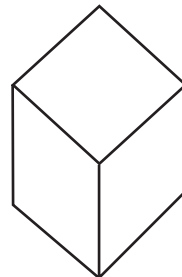

(c)

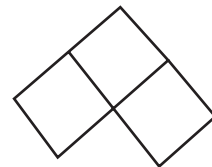

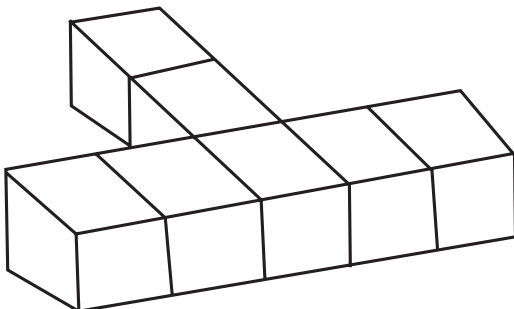

(d)

Q.5. Draw is the Top view of the given 3-D sketch?

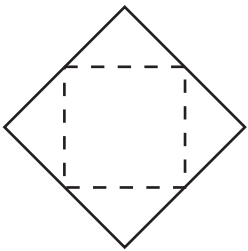
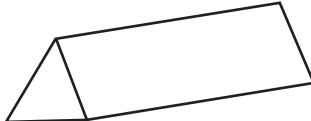
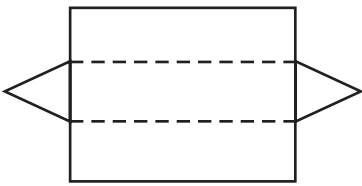

Q.6. Match the 'Nets' with their 'Boxes'

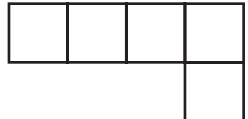
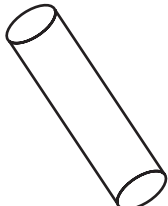
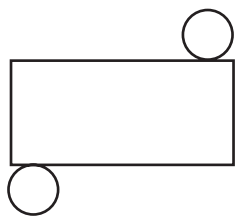
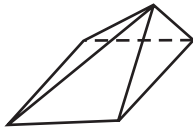
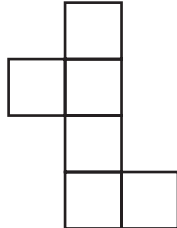
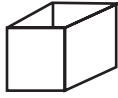
(i)		(a)	
(ii)		(b)	
(iii)		(c)	
(iv)		(d)	
(v)		(e)	



Q.7. Draw the sketch :

<u>CUBE</u>	<u>CUBOID</u>

## Chapter-10

# Tenths and Hundredths

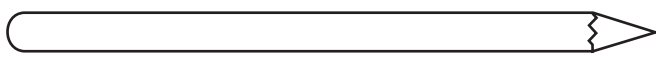
Q.1. Estimate the following lengths. Also find the actual lengths by using standard measures. Record your data in the table given below :

		My Estimate	Actual length	Difference
	 Nail			
	 Pencil			
	 ₹ 10 Note			

Q.2. Complete the following :

A.  cm = 0.7 m

B. 306 cm =  m  cm =  m.

Q.3.



Which is longer?

The sum of measure of lines in figure A or figure B.

First guess and then measure to check your guess.

Q.4. Write 3 rupee 5 paise and 3 rupee 50 paise in decimal.

Q.5. Match the following :



$\text{₹ } \frac{1}{2}$	25 paise	₹ 0.10
$\text{₹ } \frac{1}{10}$	75 paise	₹ 0.50
$\text{₹ } \frac{3}{4}$	50 paise	₹ 0.99
$\text{₹ } \frac{1}{4}$	10 paise	₹ 0.75
$\text{₹ } \frac{99}{100}$	99 paise	₹ 0.25

Arrows indicate matches:  $\text{₹ } \frac{1}{2}$  to 50 paise, 50 paise to ₹ 0.50, and ₹ 0.50 to ₹ 0.99.

Q.6. Complete :

2 cm 20 mm =  mm.

Q.7. The table shows Delhi Weather for 3 days.

3 day Delhi Weather		
		Max./Min.
Monday		35.3°C/22.8°C
Tuesday		35.8°C/23.5°C
Wednesday		35.7°C/23°C

- Which day is the hottest?
- What is the difference between maximum and minimum temperature on Monday?
- What is the lowest temperature on Wednesday?

Q.8. Fill in the blanks.

₹ 50 and 700 paise = ₹

Q.9. Sunita received a message on her mobile that she has won a prize of 125 US dollars.

(a) How much money has she won in Indian rupee if 1 US dollar = ₹ 62.50

(b) Should she rely and be happy on these type of messages?

Q.10. I am a part of whole. I am less than one half but greater than four tenths. I am a decimal with digit 2 in my hundredths place who am I ?



*Chapter-11*

# Area and its Boundary

---

---

Q.1. State True/False : The boundary of a figure is its area. True/False

Q.2.

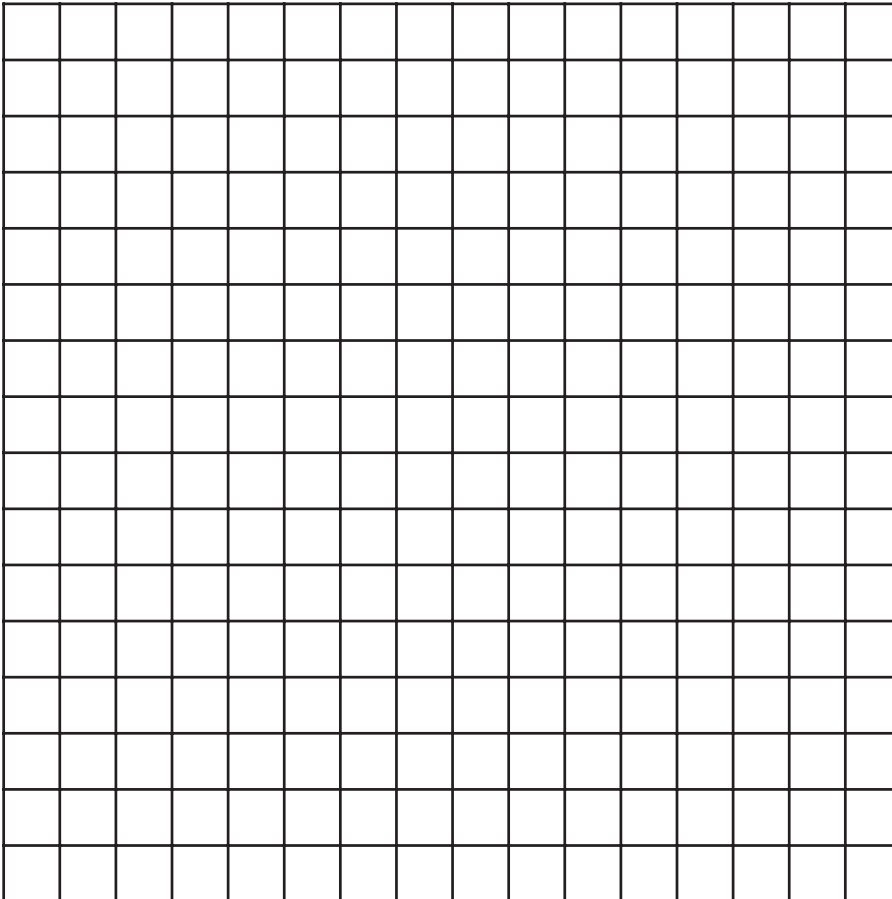

On a grid of 1 cm × 1 cm, draw the rectangles of different dimensions with Area = 16 cm<sup>2</sup>

Now, complete the following table :

S.No.	Length	Breadth	Area	Perimeter
A				
B				
C				

Which figure has the least perimeter?

Q.3. Find the missing length

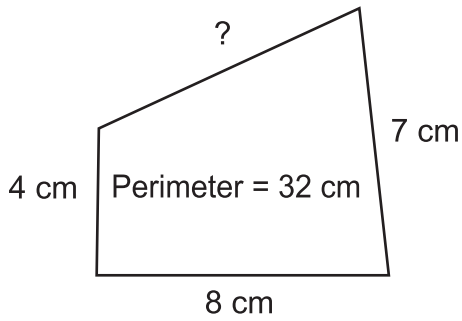

(a)

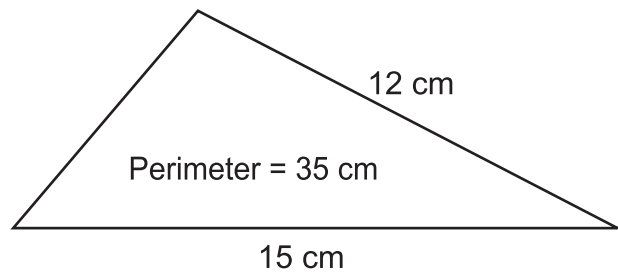

(b)

Q.4. What distance is covered by Raju if he run around the playground once?

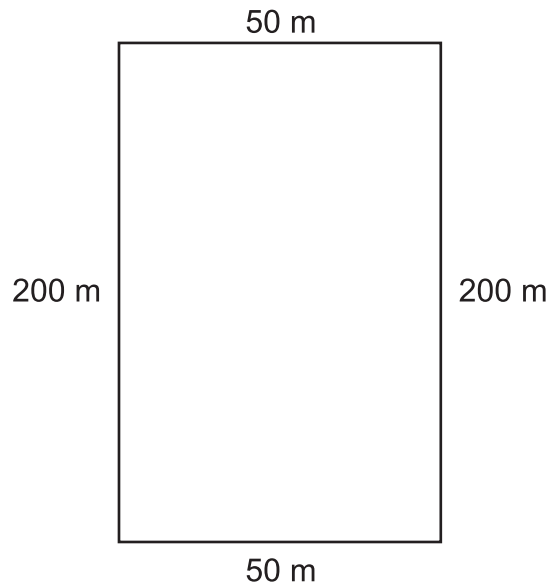

Q.5. If the areas of square A and rectangle B are same. Find the side of square A.

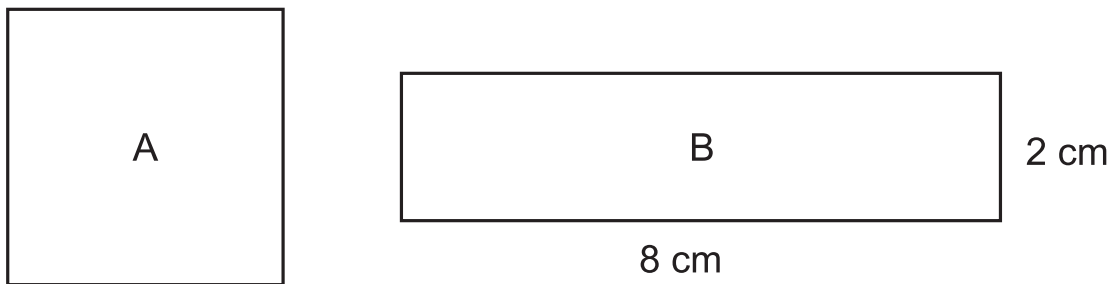

Q.6. How much area does each design cover?

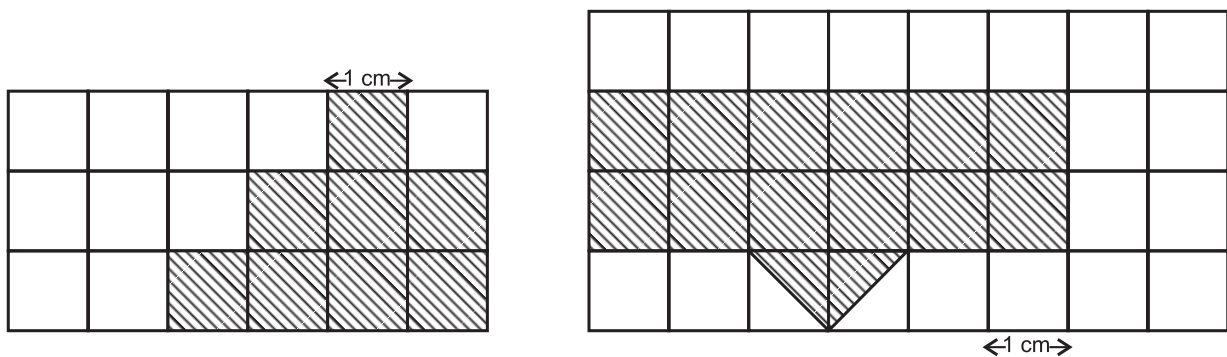

Q.7.

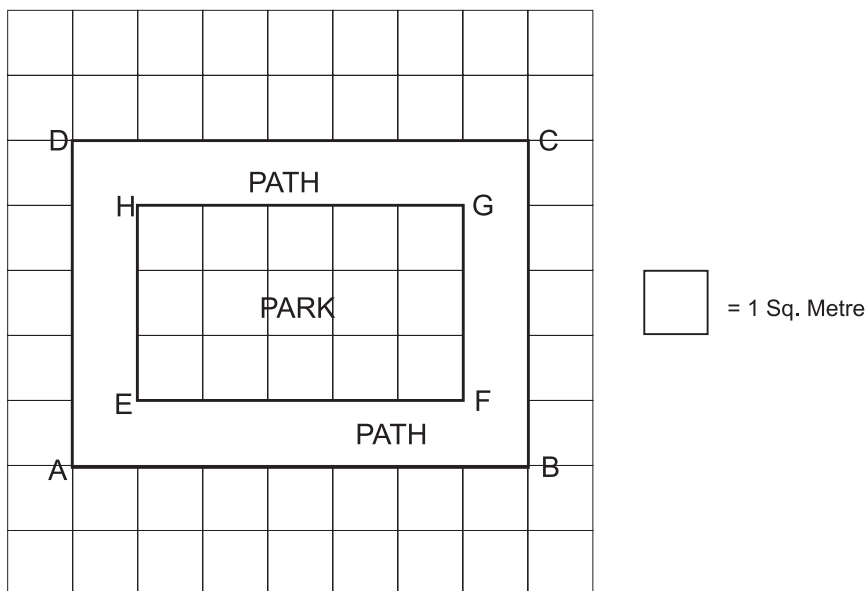

(A) Area of the path (by counting unit square) = \_\_\_\_\_ square metre

(B) Area of rectangle ABCD =  $l \times b$   
 = \_\_\_\_\_  $\times$  \_\_\_\_\_  $m^2$   
 = \_\_\_\_\_  $m^2$

(C) Area of rectangle EFGH = \_\_\_\_\_  $\times$  \_\_\_\_\_  
 = \_\_\_\_\_  $\times$  \_\_\_\_\_  
 = \_\_\_\_\_  $m^2$

(D) Area of Path = Area of Rectangle ABCD – Area of Rectangle EFGH = \_\_\_\_\_  $m^2$

Q.8. Find the perimeter of each figure. Take each side to be 1 cm.

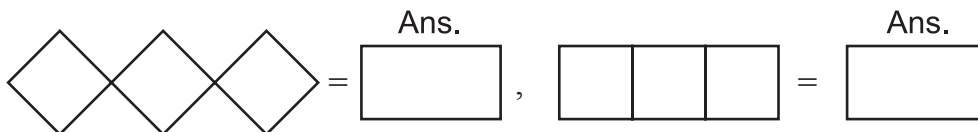

Q.9.

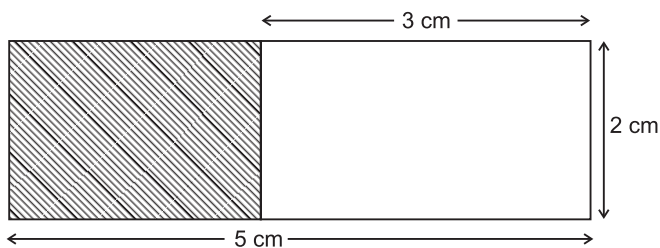

Find the area of the shaded region.

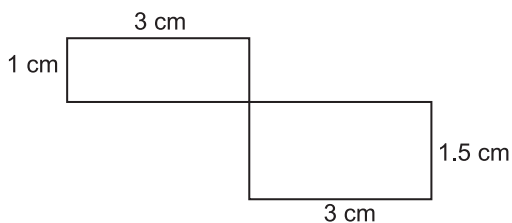

Q.10.



Find the perimeter of above the figure.

# Smart Charts

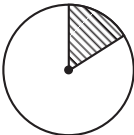
Q.1. Match the following :

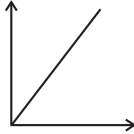
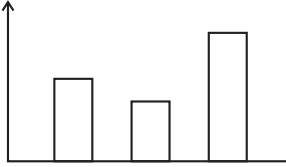
A	B
(a) Pictograph	(i) 
(b) Bar graph	(ii) 
(c) Chapati chart	(iii) 
(d) Line graph	(iv) 

Q.2. In a pictograph if  represents 50, then

     =

Q.3. Out of 100 students, 25 mentioned 'Red' as their favourite colour. Depict this on chapati chart.

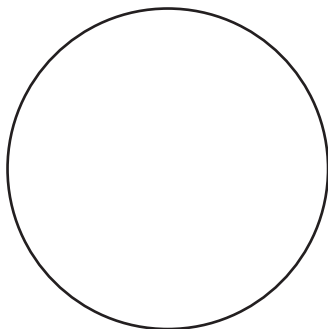

Q.4. Fill in the names on the bars. The graph shows the weight of four children

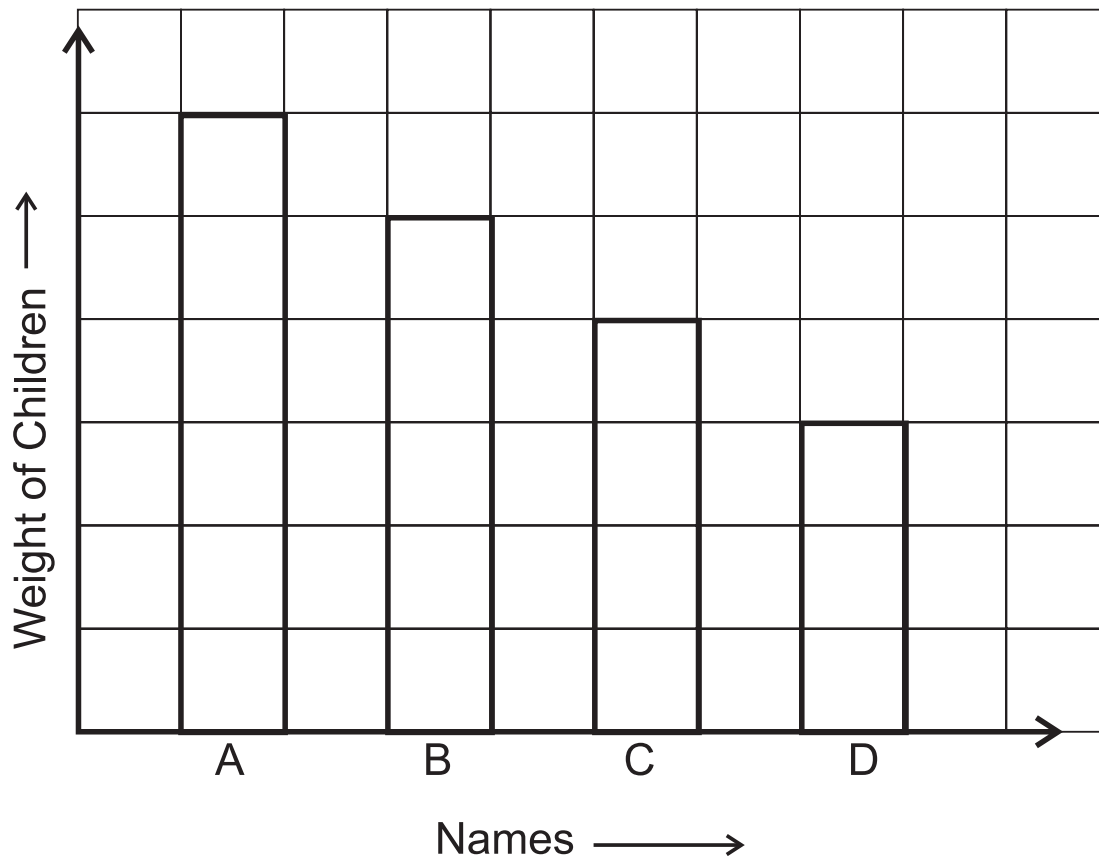

- (a) Sanya has the least weight
- (b) Dev is lighter than Jeetu but heavier than Anna

Q.5. Pradeep prepared the following table of food his family like.

	Tea	Fruit Juice	Cake	Fruit
Father	●			●
Mother	●		●	●
Grand Father	●		●	●
Sister	●		●	
Me		●		●
Brother		●	●	●

Represent the above information in the form of bar graph.

Q.6.

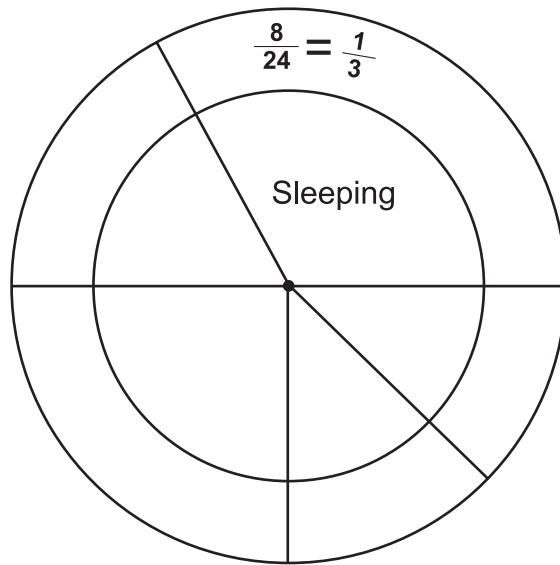

The above circle graph (pie chart) shows the time spent by PEEKU on Sunday

- 8 hours – Sleeping
- 4 hours – Reading
- 3 hours – Playing
- 3 hours – Eating, bathing etc.
- 6 hours – Spending time with Grandparents

One is filled for you complete it.

Q.7. Look at the circle graph showing how different children come to school.  
If the circle represent 100 children give the number

\_\_\_\_\_ children come by bus

\_\_\_\_\_ children come walking

\_\_\_\_\_ children use other means of transport.

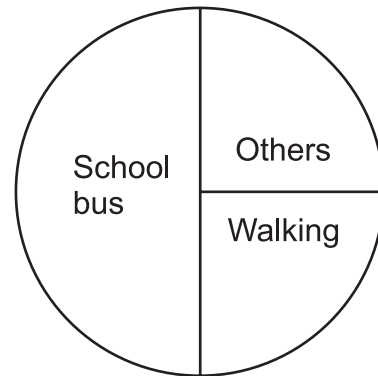

Q.8. The list shows the amount of money collected by different classes towards the donation for earth quake relief in Nepal.

Complete the bar graph and answer the question.

Class	Amount Collected
II	₹ 3000
III	₹ 6000
IV	₹ 5000
V	₹ 4000

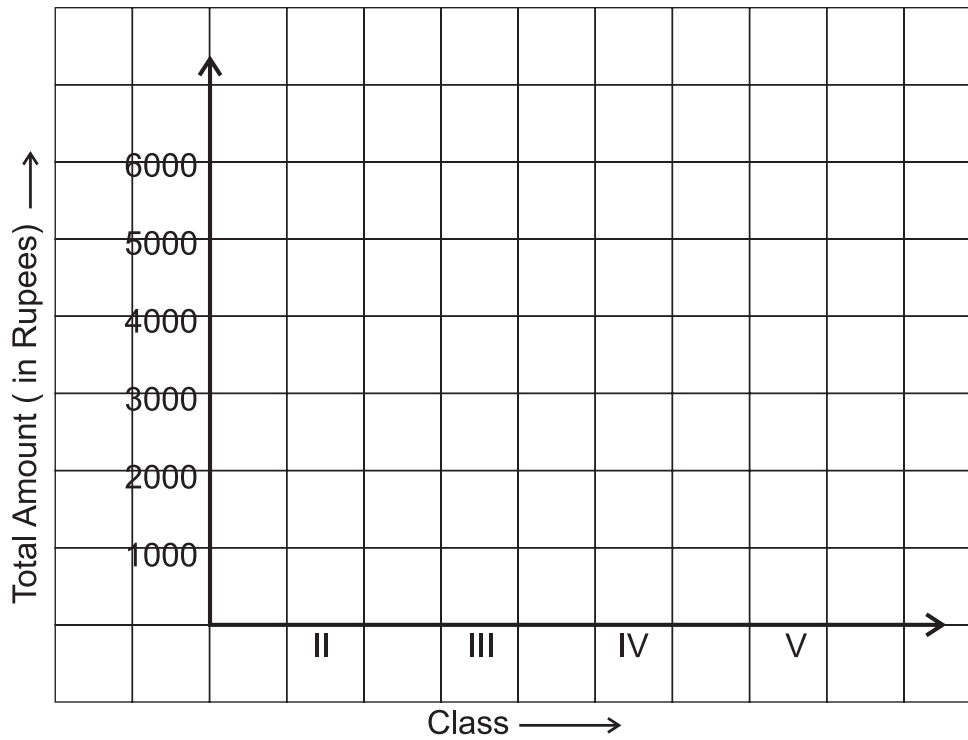

- (a) Which class collected maximum amount?
- (b) Which class collected half the amount of class III?
- (c) Which class collected the least?

Q.9. The following graph shows the 20-20 cricket match. Look at the graph and answer \_\_\_\_\_ the questions.

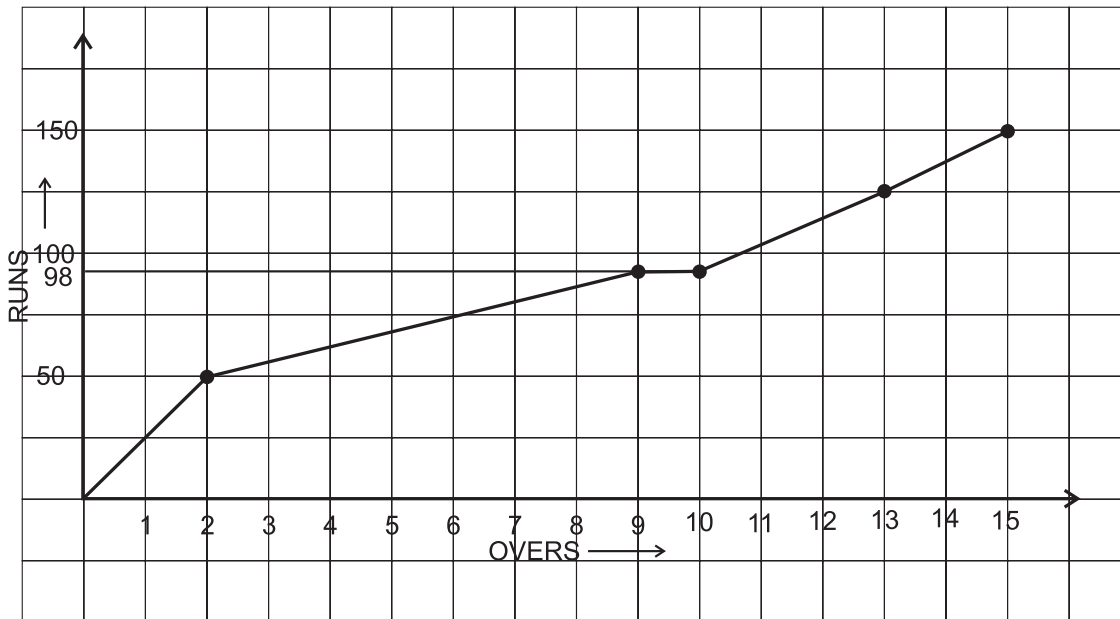

- (a) What was the score when first wicket fall?
- (b) In which over no run was scored?

Q.10. Ritu has prepared a family tree of her family.

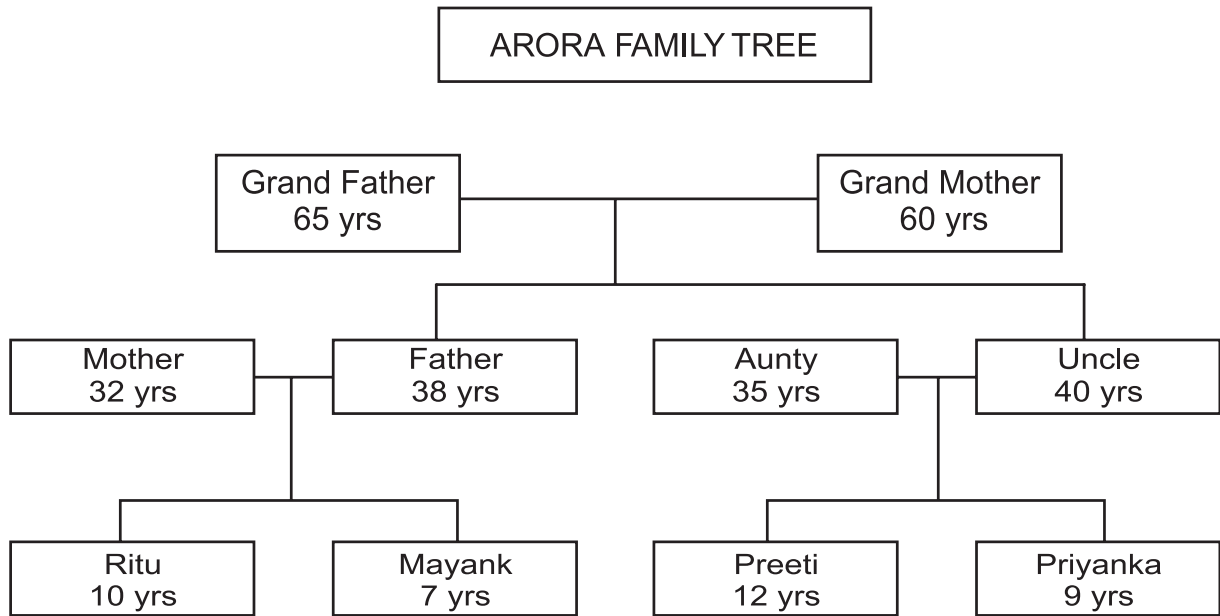

- (a) How old was father when Ritu was born?
- (b) What is the difference in ages between the youngest and the oldest person in the family?
- (c) After how many years will Ritu celebrate her 20th birthday?



## Chapter-13

# Ways to Multiply and Divide

---

---

Q.1. Multiply

$$\begin{array}{r} \text{(a)} \quad 8065 \\ \times 4 \\ \hline \hline \end{array}$$

$$\begin{array}{r} \text{(b)} \quad 63 \\ \times 15 \\ \hline \hline \end{array}$$

Q.2. Fill the boxes :

$$\begin{array}{r} 627 \\ \times 2\Box \\ \hline \end{array}$$

Q.3. Shruti has done this multiplication.

$$\begin{array}{r} 378 \\ \times 406 \\ \hline 2268 \\ 15120 \\ \hline 17388 \end{array}$$

Is the correct? If not then do the correct multiplication.

Q.4. A TV programme shows 13 advertisement during every break. There are 6 breaks. How many advertisement does it telecast?

Q.5. Divide 3480 by 12.

Q.6. Fill the boxes

$$\begin{array}{r} 8\Box \\ \hline \Box \overline{) 763} \\ \underline{-72} \\ \Box\Box \\ \underline{-36} \\ 7 \end{array}$$

Q.7.  $18 \times 22 = 396$  then  $396 \div 18 = ?$

Q.8. 
$$\begin{array}{r} 6 \\ \hline 6 \overline{) 3630} \\ \underline{- 36} \downarrow \downarrow \\ 0030 \\ \underline{- 30} \\ 00 \end{array}$$

Is the above division correct? If not, then do the correct division.

Q.9. 960 people watched the tennis match at the stadium. There were 20 rows of seats at the stadium. How many people are there in each row?

Q.10. Write the alphabet in the box by matching your answer in the table and find out who am I? Draw me.

(i) 
$$\begin{array}{r} 376 \\ \times 49 \\ \hline \square \end{array}$$
      (ii) 
$$\begin{array}{r} 460 \\ \times 304 \\ \hline \square \end{array}$$
      (iii) 
$$4 \overline{) 1236}$$
      (iv) 
$$19 \overline{) 817}$$

A 46	B 17323	C 64	D 410	E 2003	
F 18424	G 43	H 17428	I 1438	J 19867	
K 599	L 68	M 59	N 18426	O 309	
P 79	Q 840	R 139840	S 73	T 19423	
U 1786	V 15664	W 17893	X 18643	Y 20116	Z 81

## Chapter-14

# How Big? How heavy?

Q.1. Match to the most likely weight :

- |                     |             |
|---------------------|-------------|
| A. Maths book       | (i) 5000 kg |
| B. Sack of rice     | (ii) 500 g  |
| C. Strip of tablets | (iii) 50 g  |
| D. Elephant         | (iv) 5 kg   |

Q.2. 9 marbles push up 90 ml of water in a glass cylinder. The volume of one marble is \_\_\_\_\_.

Q.3. The most likely volume of medicine in the syringe is \_\_\_\_\_.

- (a) 5 ml            (b) 50 ml            (c) 100 ml

Q.4. What is the volume of given box?

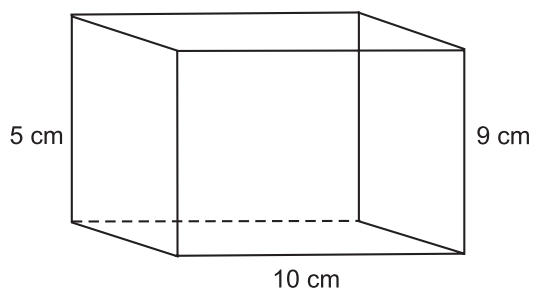

Volume of the box = \_\_\_\_\_ × \_\_\_\_\_ × \_\_\_\_\_ = \_\_\_\_\_ cm<sup>3</sup>

Q.5. The given table shows the weights of Reenu's family members :

Family member	Weight
Father	53 kg
Mother	47 kg
Brother	23 kg
Reenu	18 kg
Sister	9 kg

- (a) What is the total weight of all family members? \_\_\_\_\_
- (b) Whose weight is half the weight of Reenu? \_\_\_\_\_

- Q.6. Which is heavier and by how much?
- (a) 3 sack of rice, each weighing 50 kg.
  - (b) 4 persons with average weight 42.5 kg

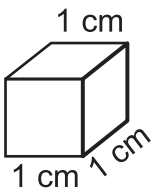
- Q.7. How many such boxes  can be fitted into the given box?

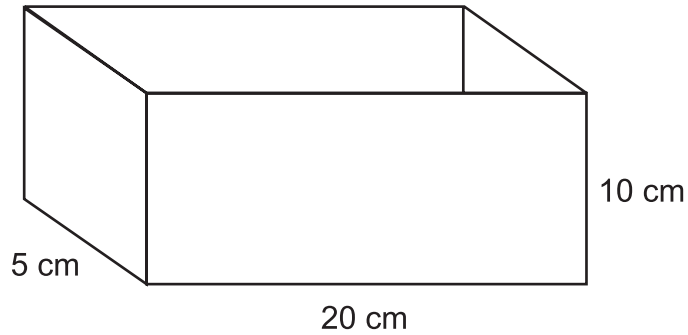

Q.8.  $2 \times \square \text{ kg} + 3 \times 15 \text{ kg} = 55 \text{ kg}.$

- Q.9. If 20 kg of wheat flour can be packed in one bag, how many bags are needed to pack 980 kg of wheat flour?

# Answer Key

## CHAPTER-1

1. (a) 1000 g  
(b) circle, oval, triangle
2. (a) ✓ (b) ✓
3. (a) ↔ (ii)  
(b) ↔ (iii)  
(c) ↔ (i)
4. (a) 6,25106  
(b) 10,25000
5. 4000 m or 4 km
6. 12, 3000 g, 3 kg
7. (1) One lakh twenty six thousand five hundred four  
(2) Four lakh sixty six thousand nine hundred three.
8. (a) 607212  
(b) 2043730
9. 850042, 950042, 1050042
10. Biggest number 975320 smallest number 203579
11. (a) 5kg + 2 kg  
(b) 5 kg + 1 kg + 1 kg  
(c) 2kg + 1 kg + 1 kg + 1 kg + 500 g + 500 g + 250 g + 250 g + 250 g + 250 g  
(d) 500 g + 500 g + 250 g + 250 g + 250 g + 250 g + 5 kg
12. 5 saplings will be drawn, 12 m
13. 2280
14. (a) 3 m 75 cm (b) 9 m 3 cm
15. (a) 450 cm (b) 701 cm

## CHAPTER-2

1. (a) ✓ (b) ✓
2. (a) ↔ (ii)  
(b) ↔ (iii)  
(c) ↔ (i)

3. (b), (c)
4. (1) 10  
(2) 6  
(3) 2
5.  $50^\circ, 140^\circ$
7. (a) less than  $90^\circ$   
(b)  $90^\circ$  or right angle  
(c) less than  $90^\circ$
8. 1. 9 'O' clock  
2.  $90^\circ$  or right angle  
3.  $180^\circ$   
4.  $30^\circ$   
5.  $45^\circ$   
6.  $90^\circ$
9.  $90^\circ$
10. (a) 5  
(b) 4

**CHAPTER-3**

1. (a) ✗ (b) ✓
2. (a) 1 square centimeter (b) area
3. (b)
4. (a)
5. (a) 4 unit<sup>2</sup> (b) 4 unit<sup>2</sup> (c) 2 unit<sup>2</sup>
6. Table
7. (a) 6 cm<sup>2</sup> (b) 5 cm<sup>2</sup> (c) 4 cm<sup>2</sup> (d) 6 cm<sup>2</sup> (e) 9 cm<sup>2</sup>

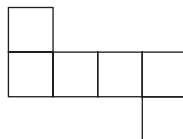
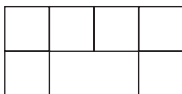
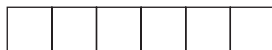
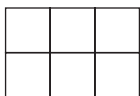

Area of all figures = 6 cm<sup>2</sup>

9. Monu's face

**CHAPTER-4**

1. (a) ✓ (b) ✗  
 2. (a) Two (b) 3  
 3. (a) ↔ (ii) ↔ (e)  
 (b) ↔ (iii) ↔ (d)  
 (c) ↔ (i) ↔ (f)

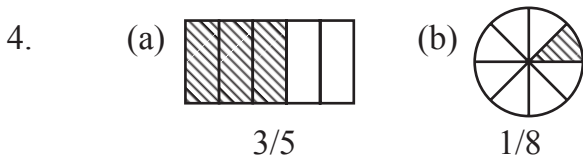

5. Student can represent in any other way.

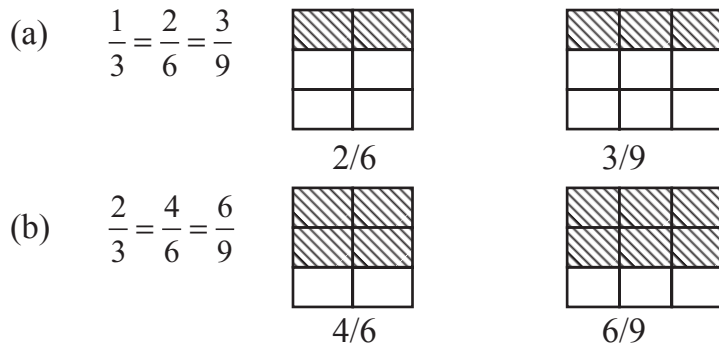

6. 10 coins  
 7. Reema - 4 toffees  
 Seema - 8 toffees  
 Herself (Pinky) → 8 toffees  
 8. 8 apples  
 9. Shading as per instructions  
 10. (a) ₹ 36 (b) ₹ 9 (c) ₹ 63 (d) ₹ 30  
 (e) ₹ 30 (f) ₹ 25

**CHAPTER-5**

1. (a) ✓ (b) ✗  
 2. WOOZ  
 3. 1001



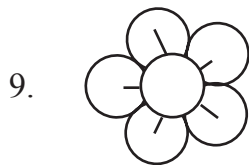
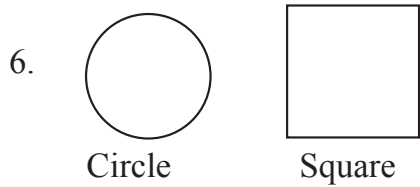
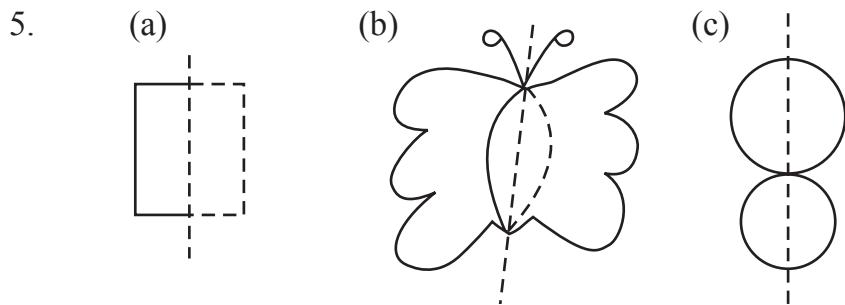

**CHAPTER-6**

1. (18), (27), (36), (45), (54), (63)

2. 1

3. 4, 2

4. True

5.

A	B
(i)	c
(ii)	d
(iii)	a
(iv)	b



6. Factors of 12 : 1, 2, 3, 4, 6, 12  
 Factors of 18 : 1, 2, 3, 6, 9, 18  
 Common factors : 1, 2, 3, 6
7. 30
8. 4, 5; 5, 4; 20, 1; less
9. 1

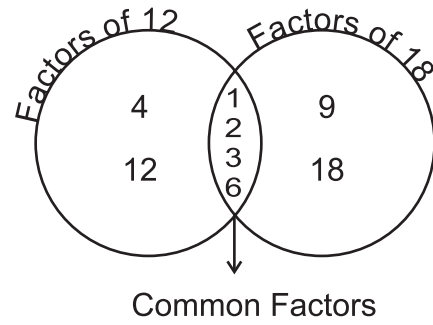

10.

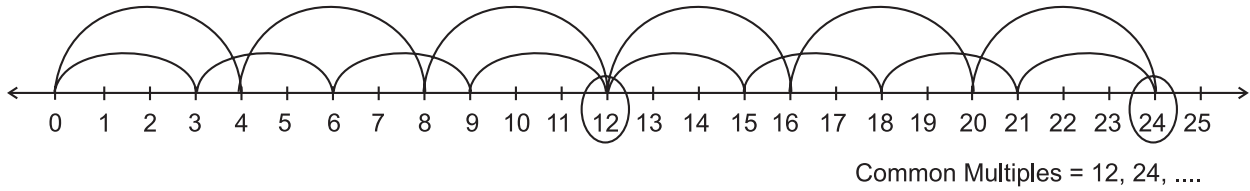

**CHAPTER-7**

1. (A) b (B) c
2. 64, 72
3. (A) 42, 39 (B) 25, 42
4. b
5. a = 42 b = 35 c = 41 e = 38 d = 43
6. a = 27 b = 29 c = 29
7. 49
8. 5 turns. 9. All of these
10. d 12. 27775, 277775

**CHAPTER-8**

1. Do yourself 2. 7 km 3. 350 km
4. A 12 cm  
 B 15 cm  
 C 20 km  
 D 108 cm
5. A. 108 m<sup>2</sup>  
 B. 27 m<sup>2</sup>  
 C. 24 m<sup>2</sup>  
 D. 36 m<sup>2</sup>  
 E. 144 m<sup>2</sup>

## CHAPTER-9

1. b
2. yes
3. false
4. c

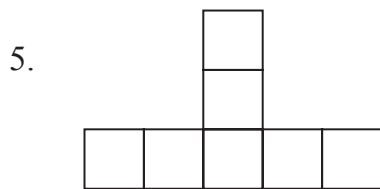

6. (i) ↔ d                      (ii) ↔ a                      (iii) ↔ e  
(iv) ↔ c                      (v) ↔ b

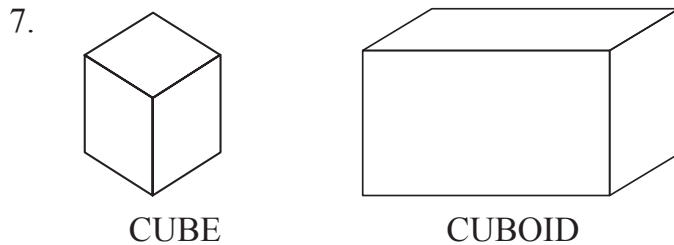

## CHAPTER-10

1. Do it yourself
2. A. 70                      B. 3 m 6 cm = 3.06 m
3. Fig. A
4. ₹ 3.05, ₹ 3.50

5. ₹  $\frac{1}{2}$  = 50 paise = ₹ 0.50

₹  $\frac{1}{10}$  = 10 paise = ₹ 0.10

₹  $\frac{3}{4}$  = 75 paise = ₹ 0.75

₹  $\frac{1}{4}$  = 25 paise = ₹ 0.25

₹  $\frac{99}{100}$  = 99 paise = ₹ 0.99

6. 40 mm
7. (a) Tuesday (b) 12.5°C (c) 23°C
8. ₹ 57
9. (a) ₹ 7812.50 (b) No
10. 0.42

### CHAPTER-11

1. False
2.

	<i>Length</i>	<i>Width</i>	<i>Area</i>	<i>Perimeter</i>
A.	16 cm	1 cm	16 cm <sup>2</sup>	34 cm
B.	8 cm	2 cm	16 cm <sup>2</sup>	20 cm
C.	4 cm	4 cm	16 cm <sup>2</sup>	16 cm

SQUARE C has least perimeter.
3. (a) 4 cm (b) 8 cm
4. 500 m
5. 4 cm
6. 8 square cm, 13 square cm
7. (A) 20 m<sup>2</sup> (B) 7 × 5, 35 m<sup>2</sup> (C) 5 × 3, 15 m<sup>2</sup> (D) 20m<sup>2</sup>
8. 12 cm, 8 cm
9. 4 sq. cm
10. 17cm

### CHAPTER-12

1. (a) ↔ (ii), (b) ↔ (iv), (c) ↔ (i), (d) ↔ (iii)
2. 250
3. Draw yourself
4. A. JEETU  
B. DEV  
C. ANNA  
D. SANYA
5. Draw yourself
6. Do yourself
7. 50  
25  
25

8. (a) III (b) II (c) II  
 9. (a) 50 (b) 10  
 10. (a) 28 yrs (b) 58 yrs (c) 10 yrs

**CHAPTER-13**

1. (a) 32260 (b) 945  
 2. Do yourself  
 3. Do yourself  
 4. 78  
 5. 290  
 6. Do yourself  
 7. 22  
 8. Do yourself  
 9. 48  
 10. (i) F (ii) R (iii) O (iv) G

**CHAPTER-14**

1. A. ↔ (ii) B. ↔ (iv) C. ↔ (iii) D. ↔ (i)  
 2. 10 ml  
 3. (a)  
 4. Length × breadth × height = 450 cm<sup>3</sup>  
 5. (A) 150 kg (B) Sister  
 6. (B), By 20 kg  
 7. 1000 boxes  
 8. 5  
 9. 49 bags